



AK120-1 v4

INSTRUKCJA MONTAŻU CZOŁOWEGO
FRONTAL ASSEMBLY MANUAL
MANUAL DE MONTAJE FRONTAL
INSTRUCTION DE POSE EN APPLIQUE
MANUALE DI MONTAGGIO FRONTALE

PL

Instrukcja montażu elastycznej kurtyny przeciwpożarowej AK120-1 v4 przedstawia jeden z rekomendowanych sposobów składania bramy. Przed rozpoczęciem montażu należy zapoznać się w całości z niniejszą instrukcją oraz zweryfikować czy wymiary otworu są zgodne z wymiarami zamówionej bramy i wymiarami nadproża i ścian. Instalacja bramy powinna odbywać się na równej powierzchni oraz oczyszczonej ze wszelkich elementów i zabrudzeń, które mogą spowodować uszkodzenia. Niektóre z dostarczanych elementów wymagają docięcia bezpośrednio na budowie. W zależności od wielkości bramy i sposobu montażu elementy złączne mogą odbiegać od prezentowanych na kolejnych stronach. W trakcie regulacji krańcówek (punkt 11) należy unikać przegrzania silnika. Zalecane jest opuszczanie bramy po odłączeniu zasilania.

EN

The assembly instruction for the flexible fireproof curtain AK120-1 v4 presents one of the recommended ways of fitting together the gate. Before starting the installation, read this manual in its entirety and verify whether the dimensions of the opening are consistent with the dimensions of the ordered gate and the dimensions of the lintel and walls. The gate should be installed on a flat surface that is clean of any elements and dirt that may cause damage. Some of the delivered elements require cutting directly on the construction site. Depending on the size of the gate and the method of installation, the fasteners may differ from those presented on the following pages. When adjusting the limit switches (point 11) avoid overheating of the engine. It is recommended to lower the gate after disconnecting the power supply.

ES

Las instrucciones de montaje de la cortina flexible cortafuego AK120-1 v4 presentan una de las formas recomendadas de montar la cortina. Antes de comenzar la instalación, lea íntegramente este manual y verifique si las dimensiones del hueco coinciden con las dimensiones de la puerta solicitada y con las dimensiones del dintel y las paredes. La cortina debe instalarse sobre una superficie plana y limpia de elementos y suciedad que puedan provocar daños. Algunos de los elementos entregados requieren corte directamente en la obra. Dependiendo del tamaño de la puerta y del método de fijación, los elementos de unión pueden diferir de los presentados en las siguientes páginas. Al ajustar los finales de carrera (punto 11) evite el sobrecalentamiento del motor. Se recomienda bajar la cortina después de desconectar la alimentación eléctrica.

FR

Cette instruction d'installation présente une des manières recommandées de montage du rideau coupe-feu textile à enroulement AK120-1 v4. Avant de procéder à l'installation, il est nécessaire de se familiariser avec le document entier et de vérifier si les dimensions de la baie correspondent bien aux dimensions du rideau commandé ainsi qu'aux dimensions du linteau et des murs. Le montage du rideau devrait se faire sur une surface lisse, propre, libre de tout dispositif et de toute saleté qui pourraient l'endommager. Certains éléments fournis sont à être découpés et adaptés sur le chantier. En fonction des dimensions du produit et du type de pose les fixations livrées peuvent différer de celles présentées sur les pages qui suivent. Il faut éviter de surchauffer le moteur lors du réglage des fins de course (voir point 11). Il est recommandé de faire descendre le rideau une fois l'alimentation coupée.

IT









Le istruzioni di installazione della cortina elastica avvolgibile AK120-1 v4 presentano una delle modalità di montaggio consigliate per la tenda. Prima di iniziare l'installazione, leggere interamente questo manuale e verificare che le dimensioni di apertura siano corrispondenti a quelle della tenda ordinata e anche le dimensioni dell'architrave e delle pareti. La tenda deve essere installata su una superficie piana, pulita da qualsiasi elemento e sporcizia che potrebbero causare danni. Alcuni degli elementi consegnati devono essere tagliati direttamente in cantiere. Sulla base delle dimensioni della tenda e del metodo di installazione, gli elementi di fissaggio possono differire da quelli presenti nelle pagine successive. Quando si regola il finecorsa (punto 11) evitare il surriscaldamento del motore. È raccomandato di abbassare la tenda e disconnettere la corrente elettrica.



Wymagane otworowanie
Drilling required
Necesario taladrar
Perçage nécessaire
Necessaria perforazione



Wymagane cięcie
Cutting required
Necesario cortar
Découpe nécessaire
Necessario taglio

A		Śruba M6x16 z gniazdem imbusowym	Hex drive bolt M6x16	3AX001
B		Wkręt 5,5x19	Tapping screw 5,5x19	3FZ005
C		Wkręt samowiercący 4,2x13	Self-drilling screw 4,2x13	3FY001
D		Wkręt samowiercący 6,3x25 z łbem sześciokątnym podkładowym	Hexagon washer head self-drilling screw 6,3x25	3FY009
E		Wkręt samowiercący 5,5x50	Self-drilling screw 5,5x50	3FX001
F		Kotwa pierścieniowa M10x120	Wedge anchor M10x120	3HZ005
G		Kotwa pierścieniowa M12x140	Wedge anchor M12x140	3HZ007
H		Łącznik ościeżnic 10x72	Frame connector 10x72	3HY001

1

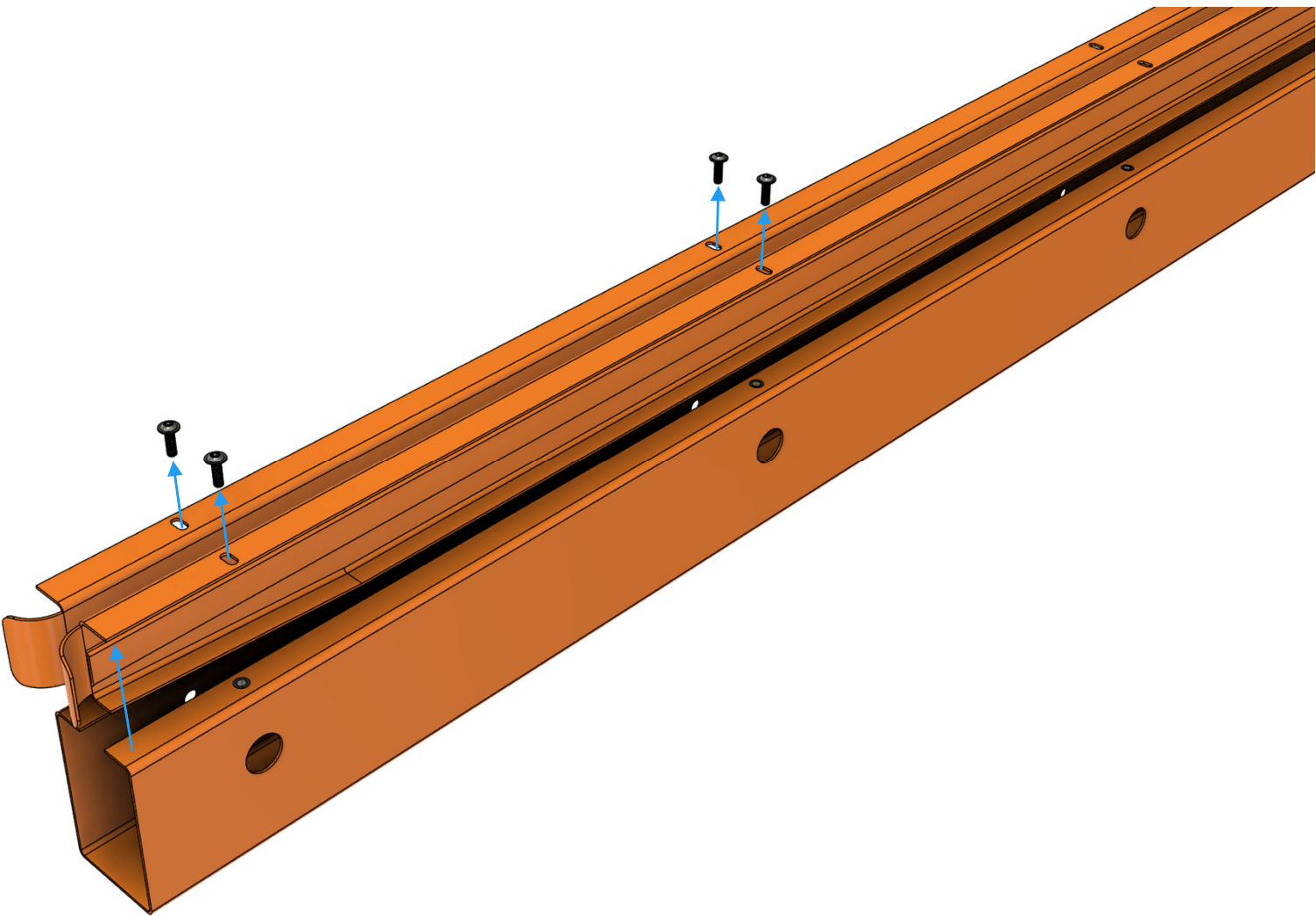

2

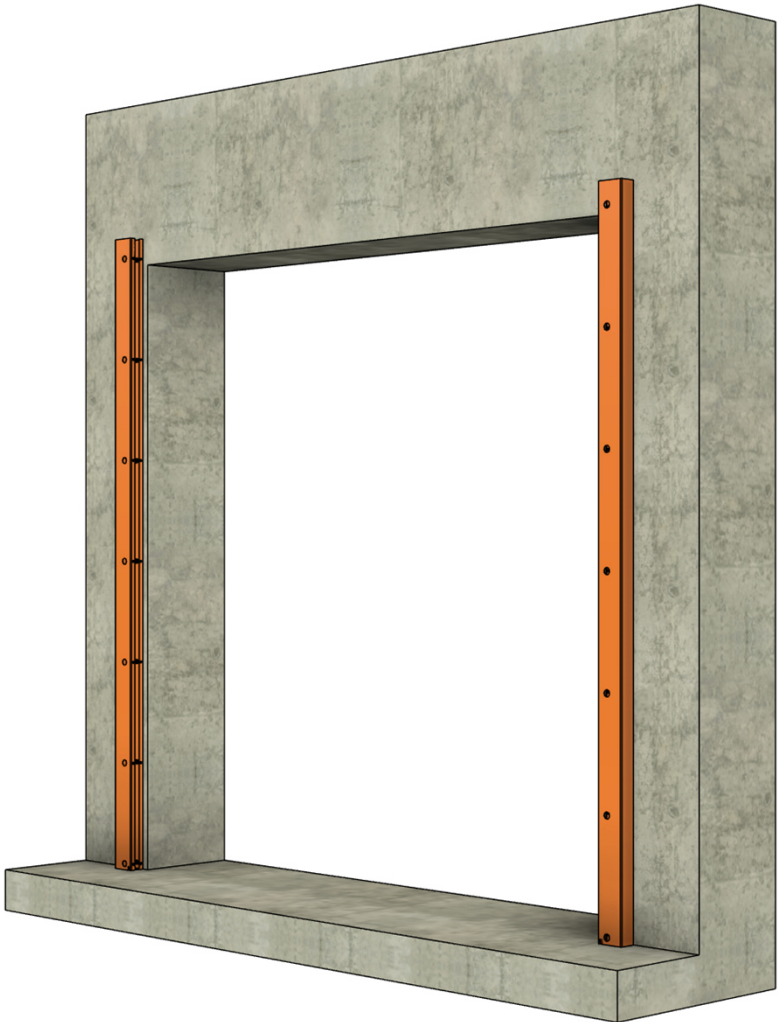
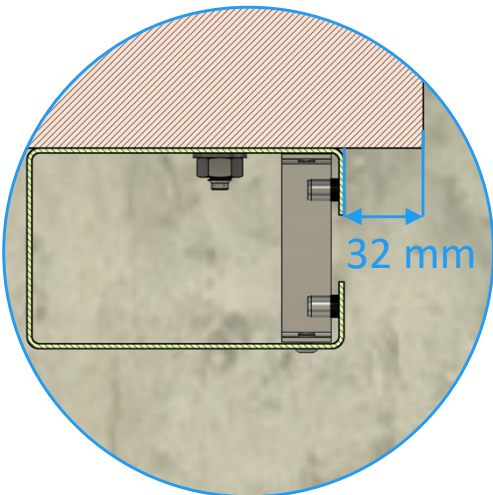
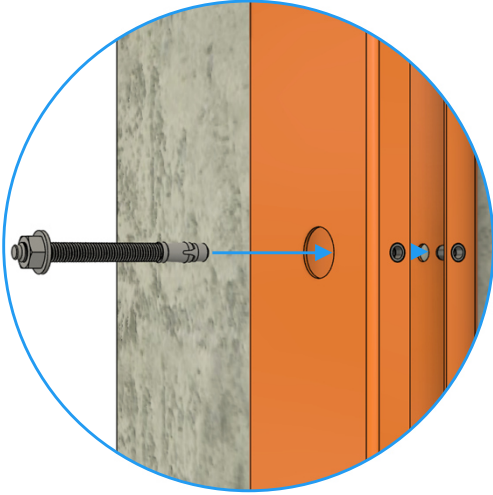

3

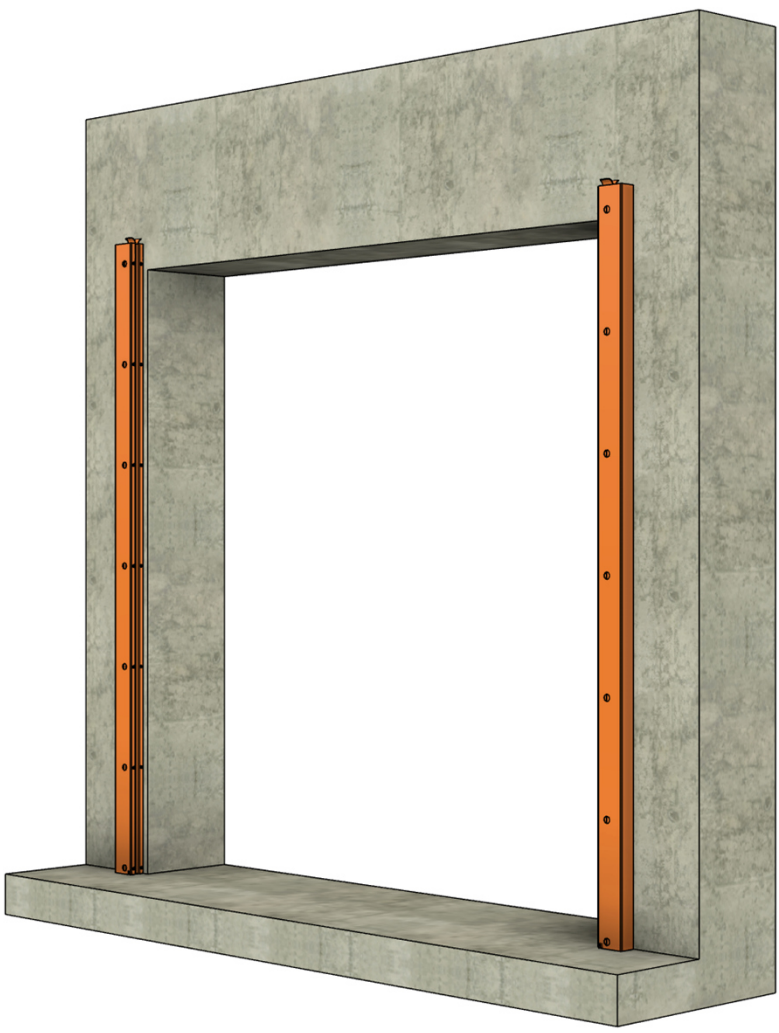
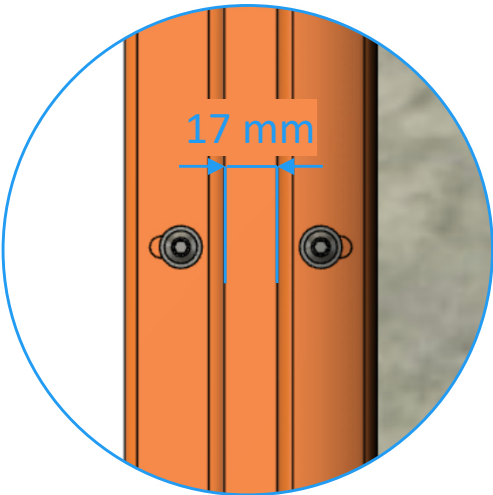
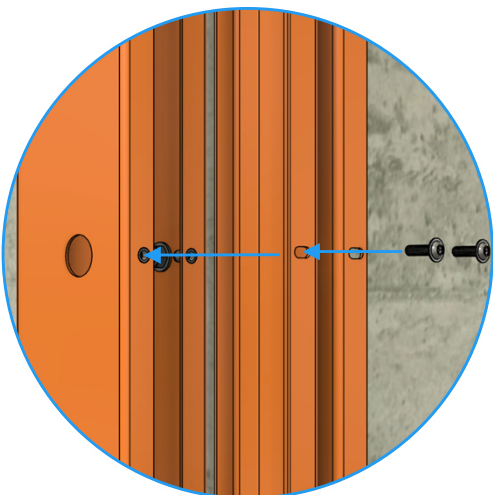

4

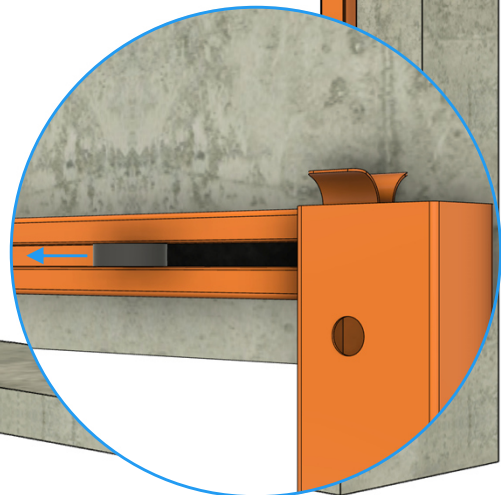
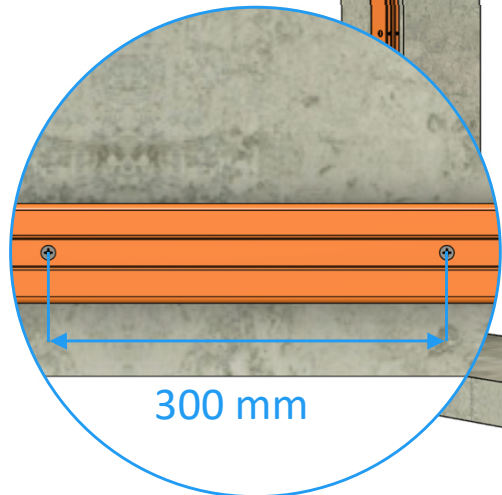
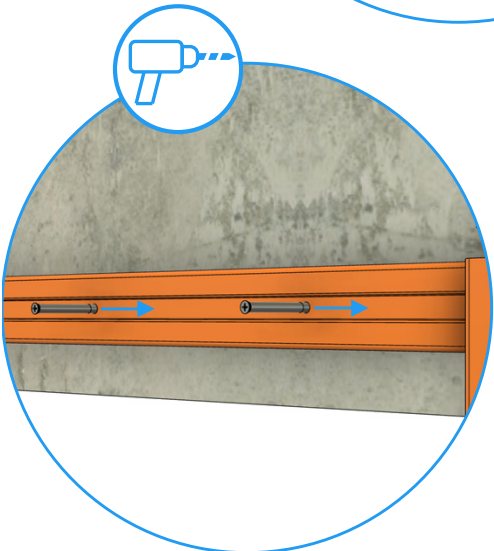
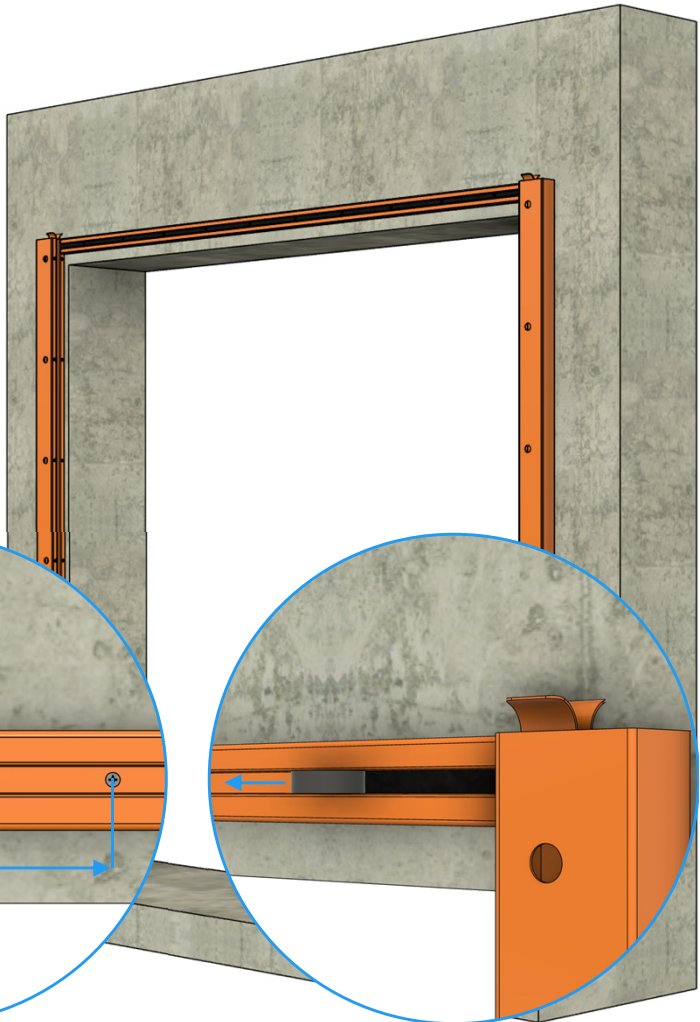
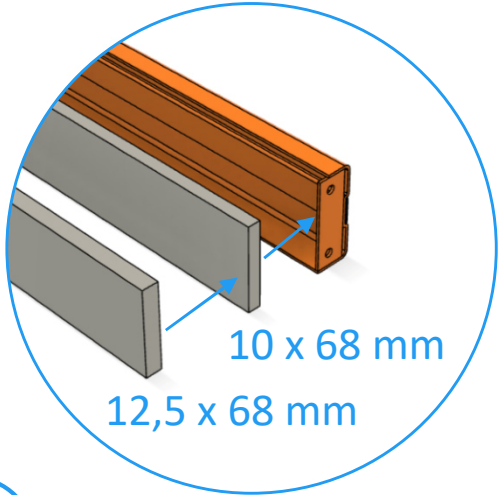

5

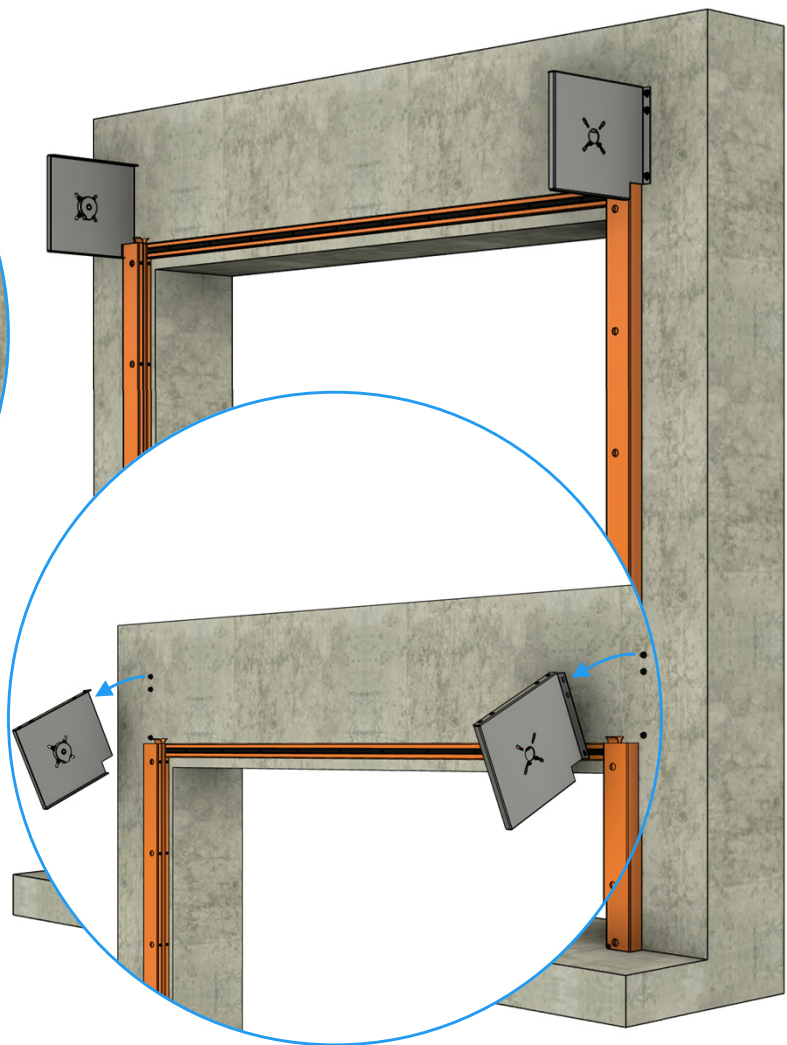
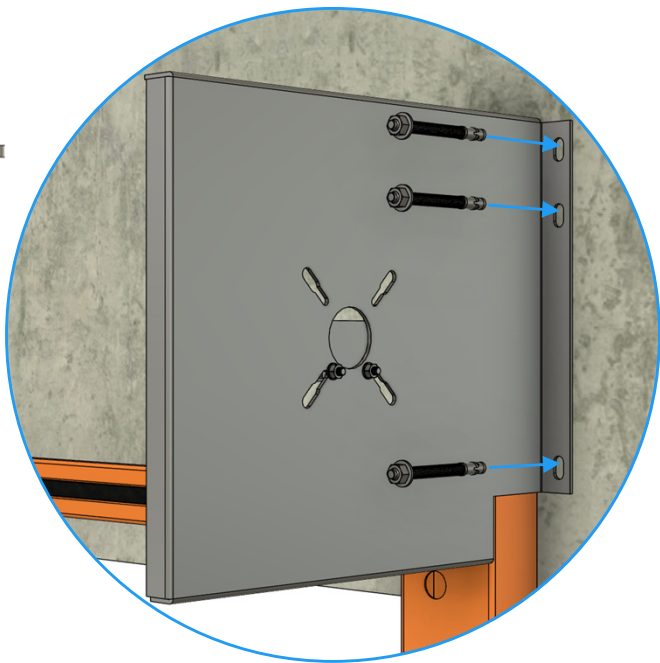

6a

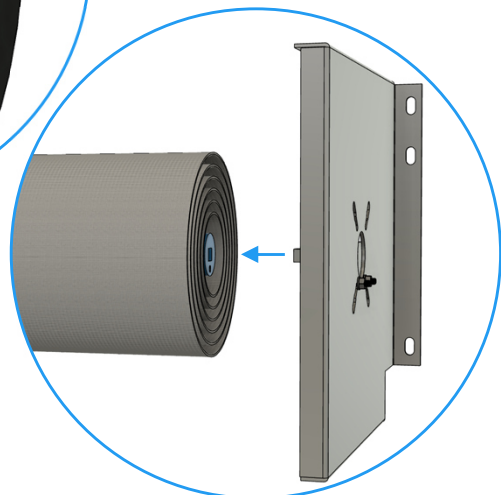
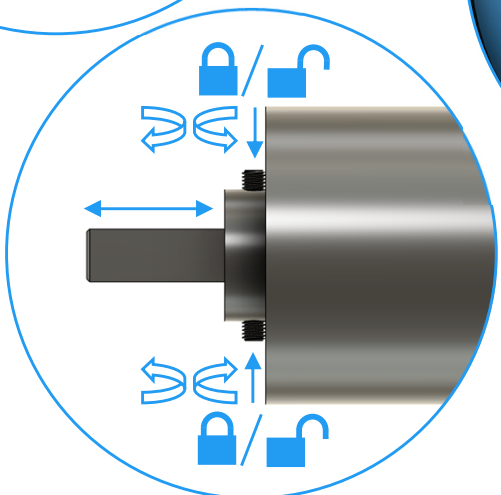
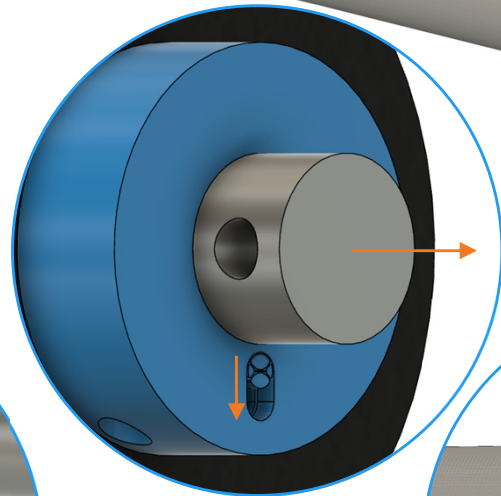
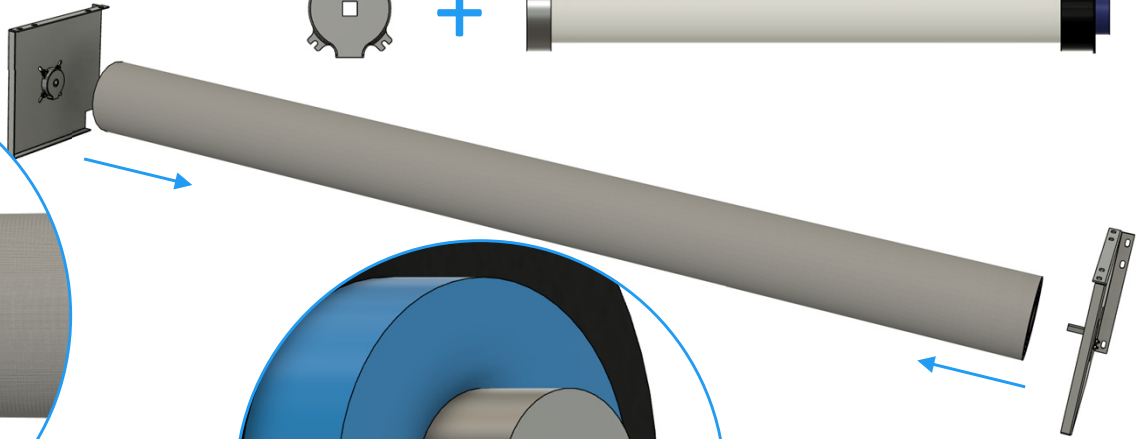
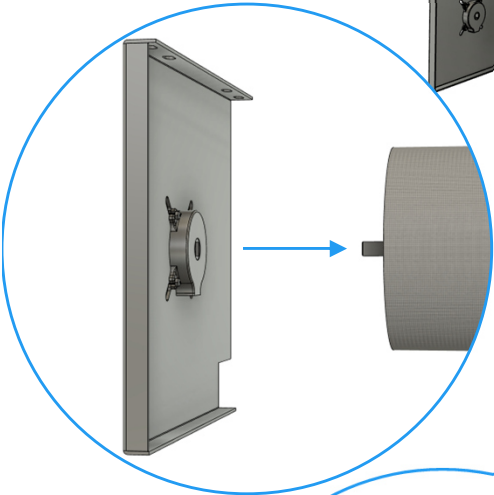

6b

2 x

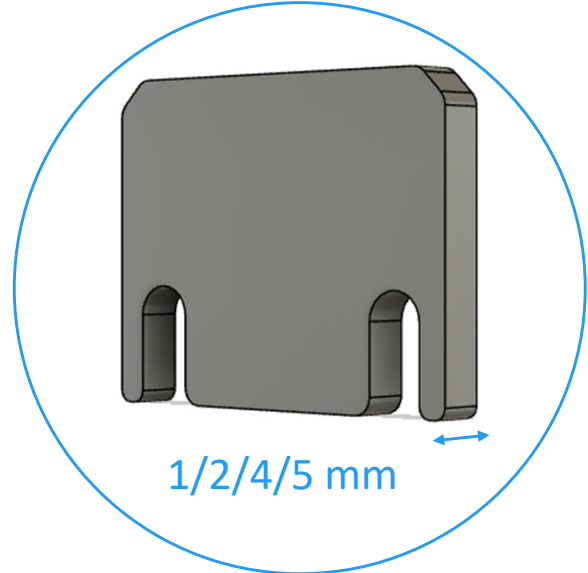
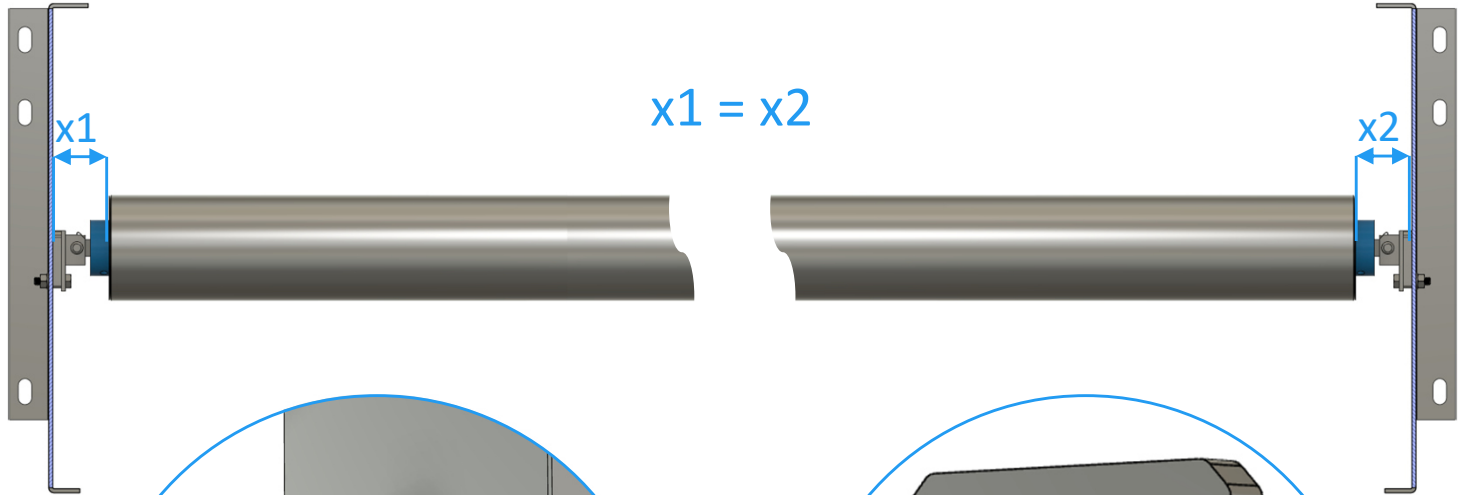
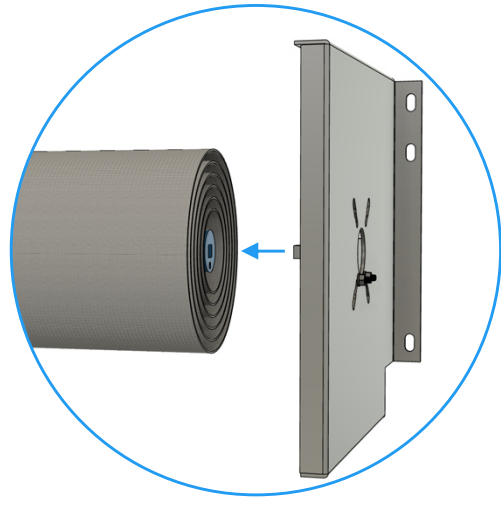
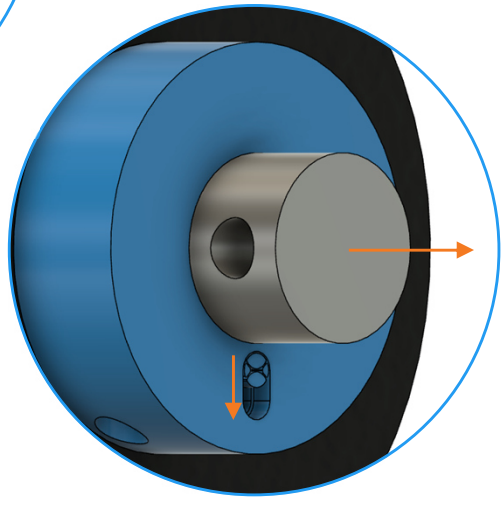
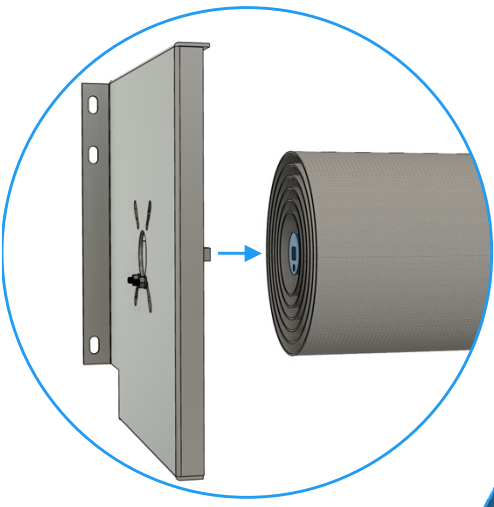
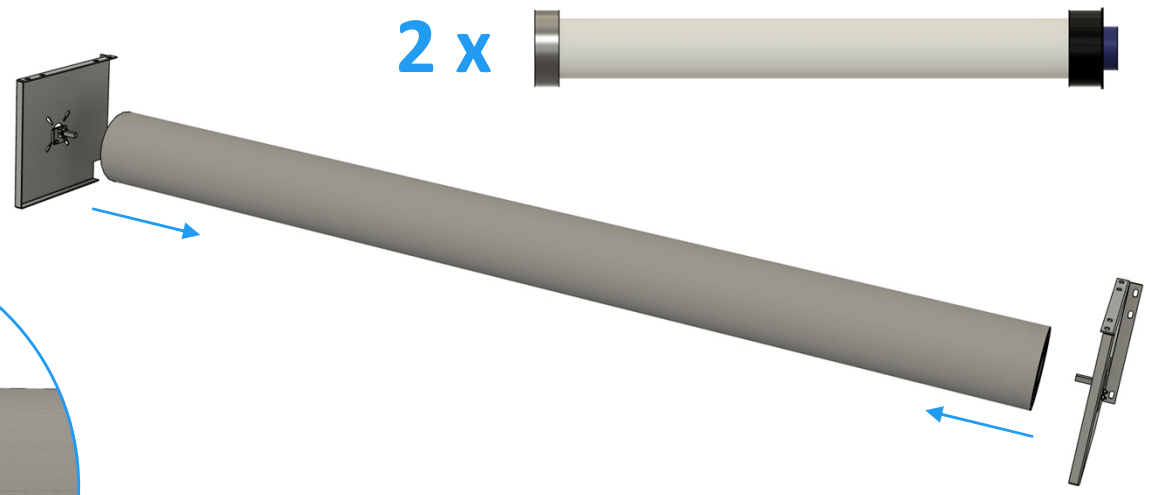

7

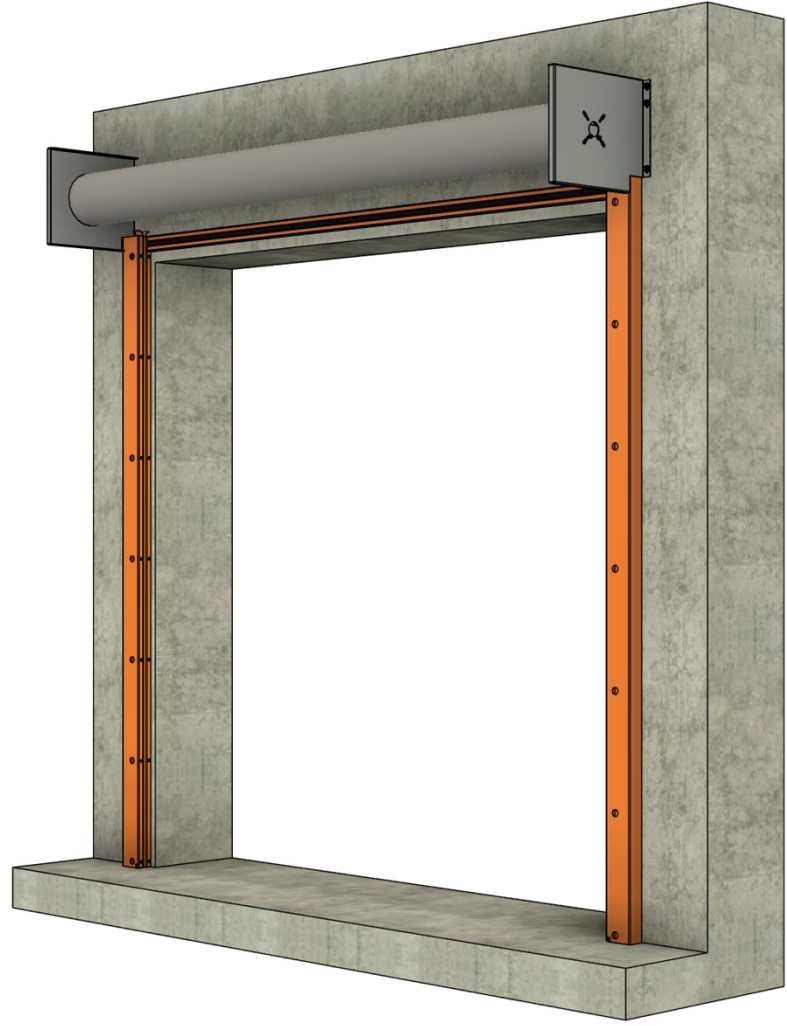
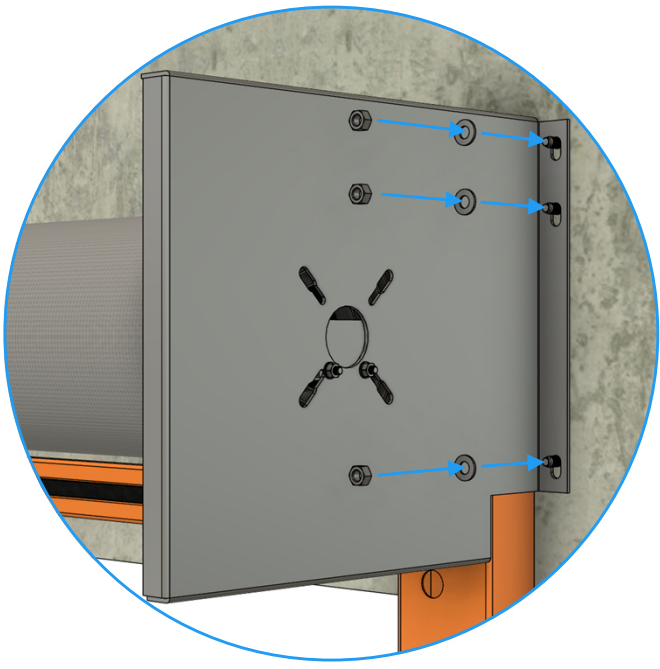

8

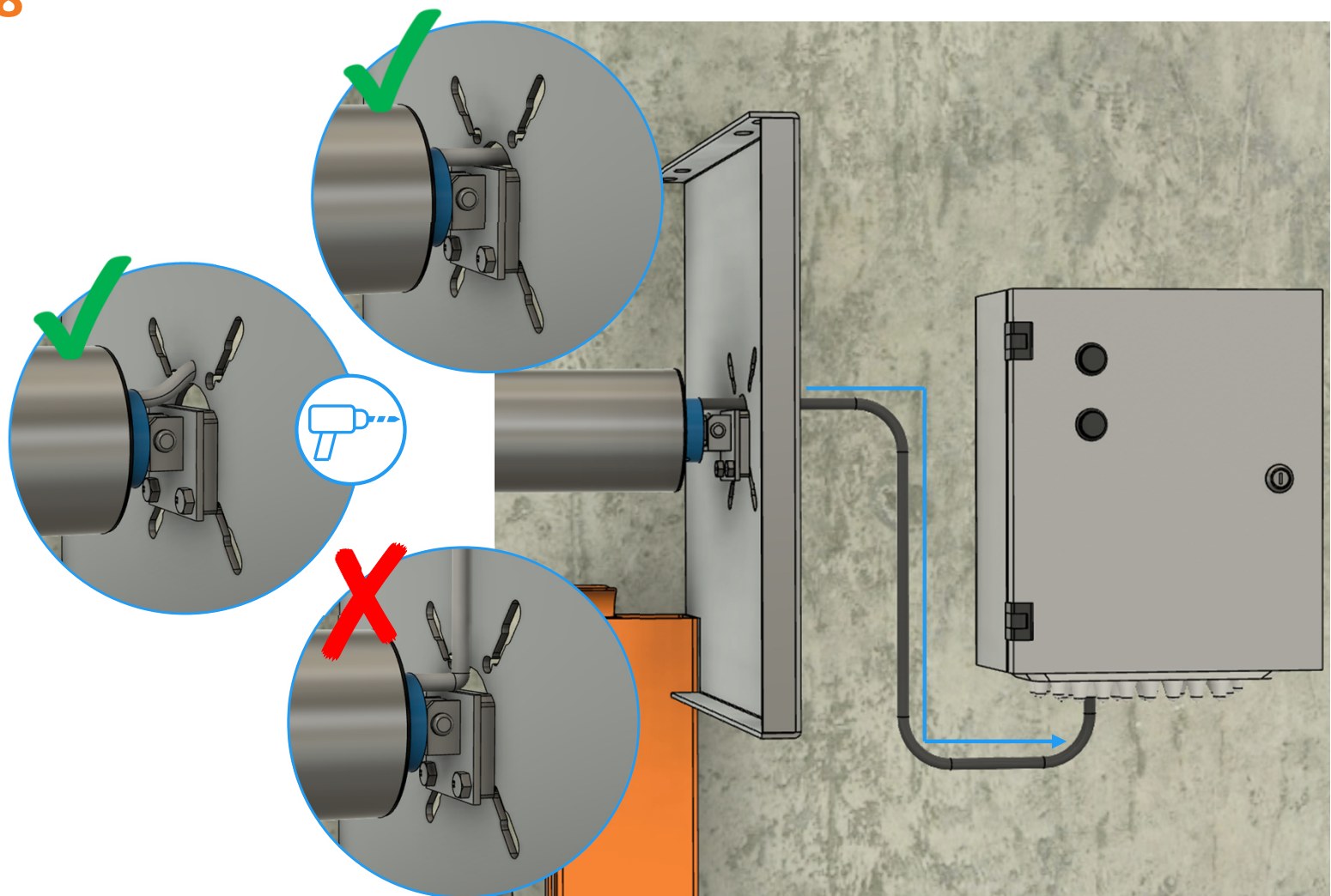

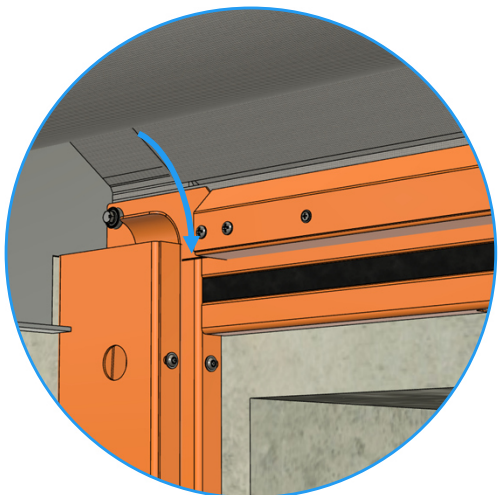
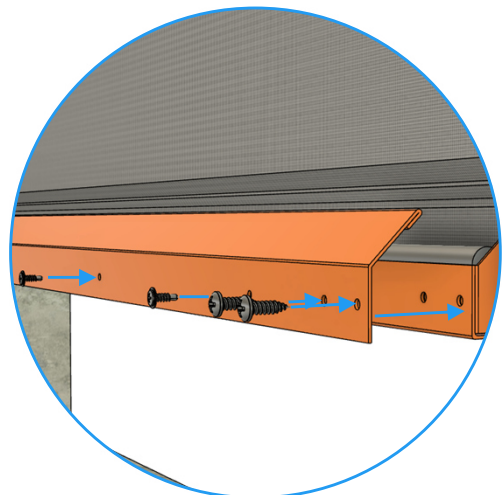
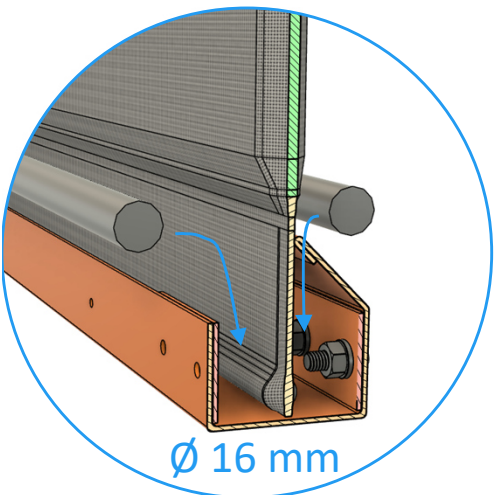
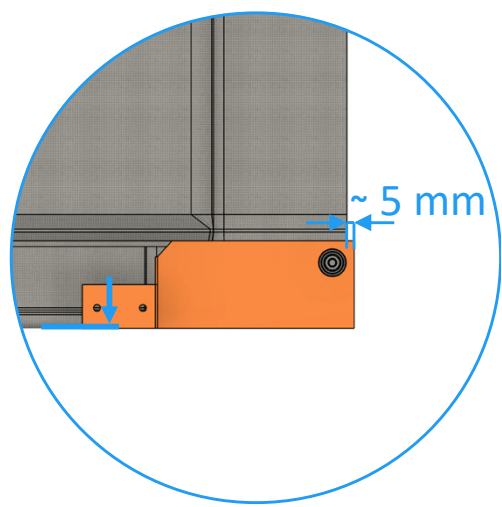
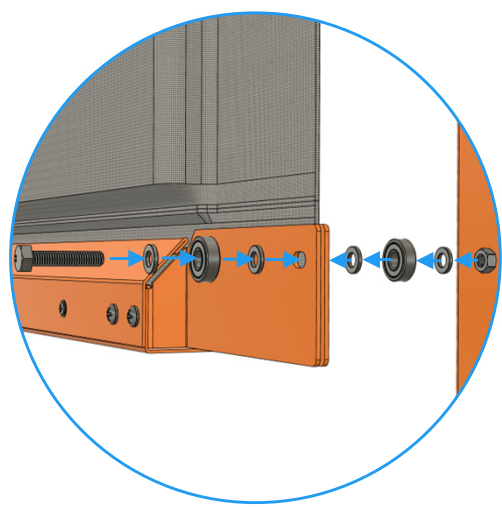
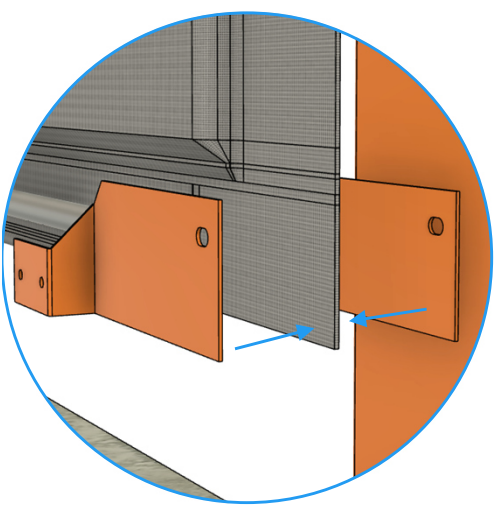
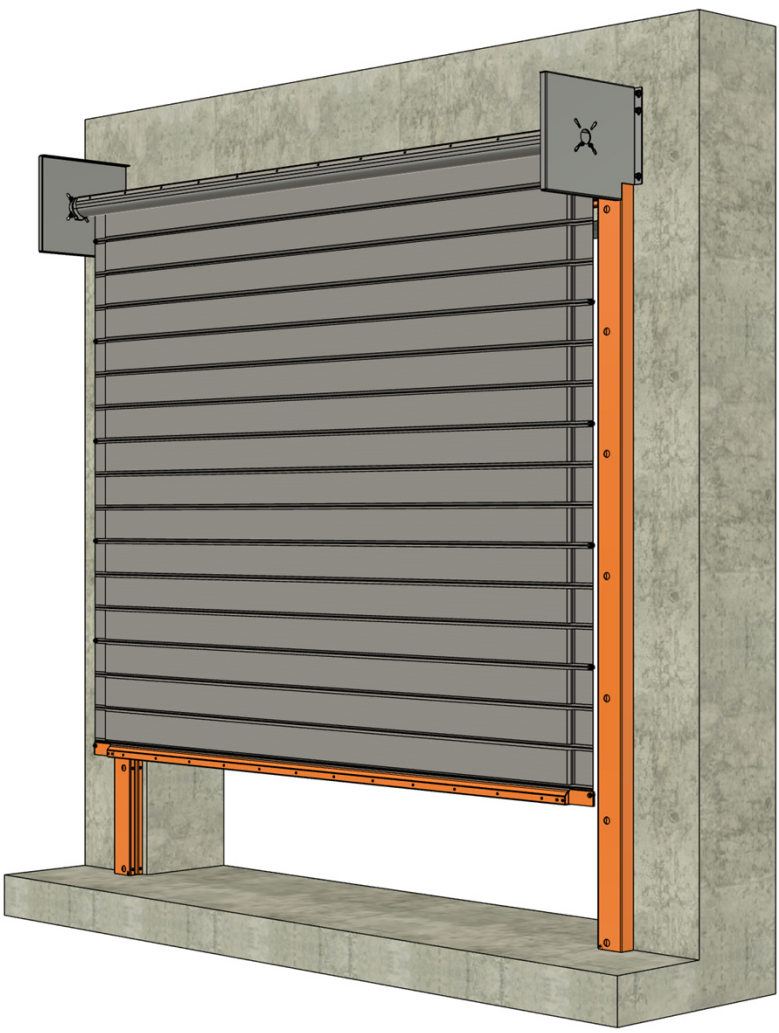
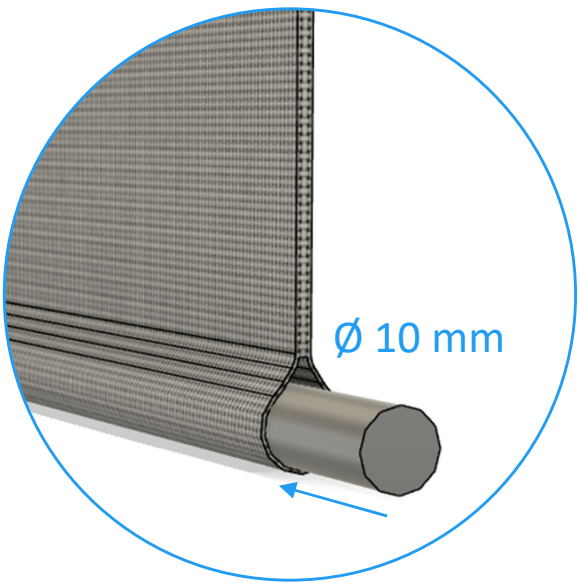
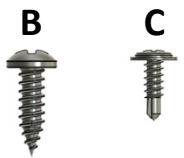

10

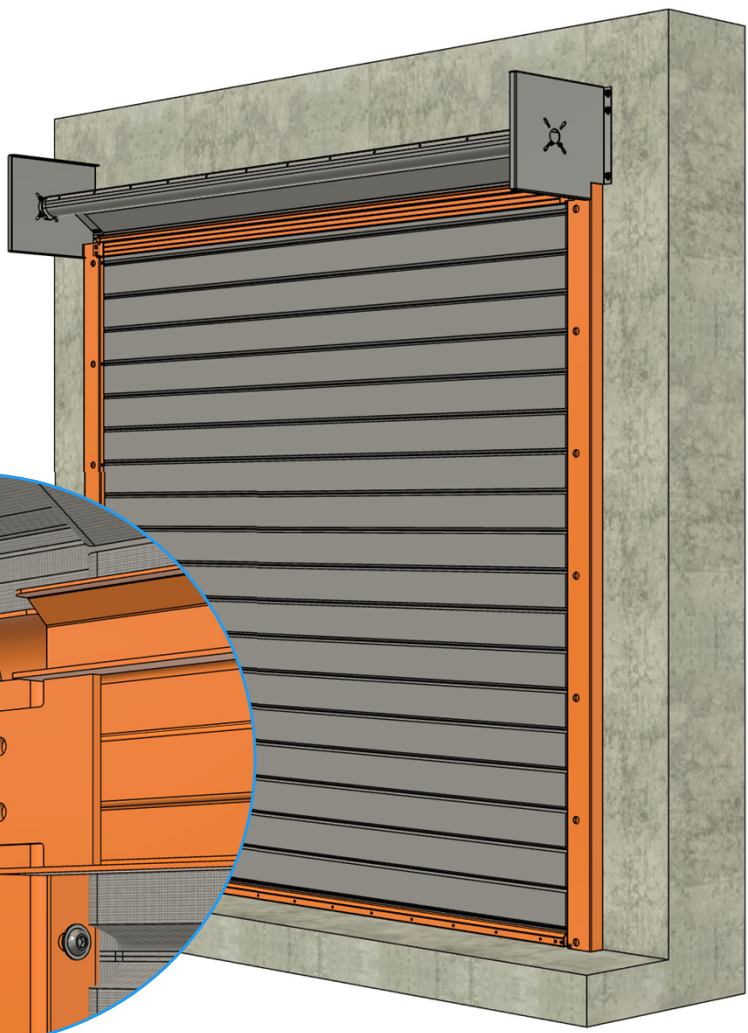
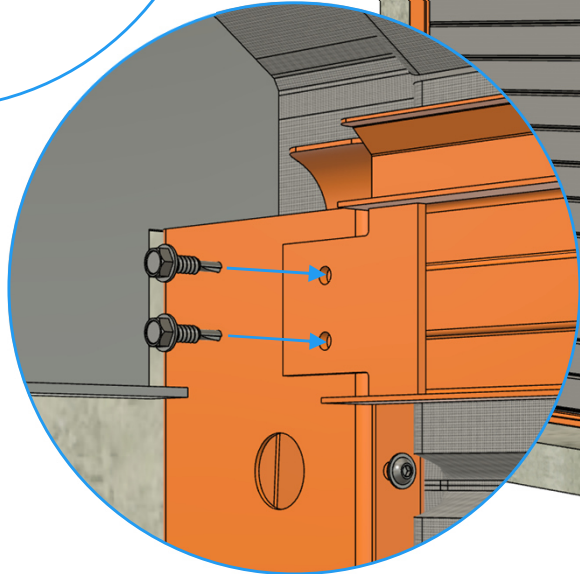
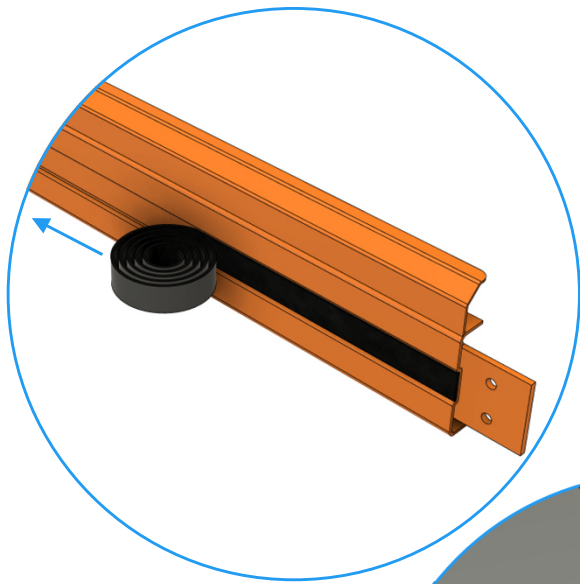
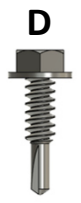

11

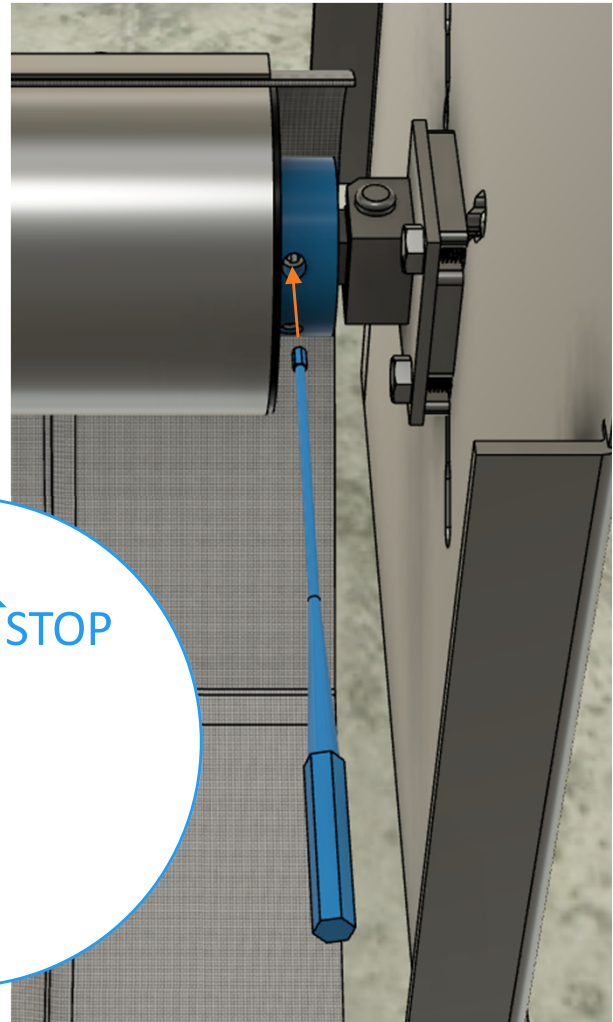
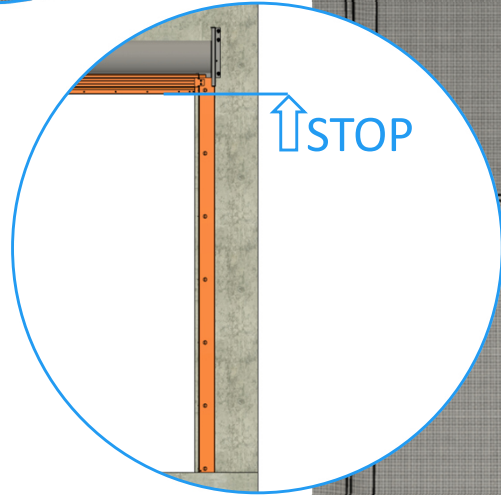
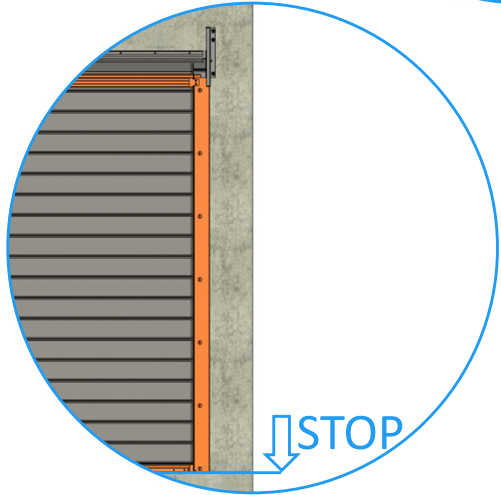
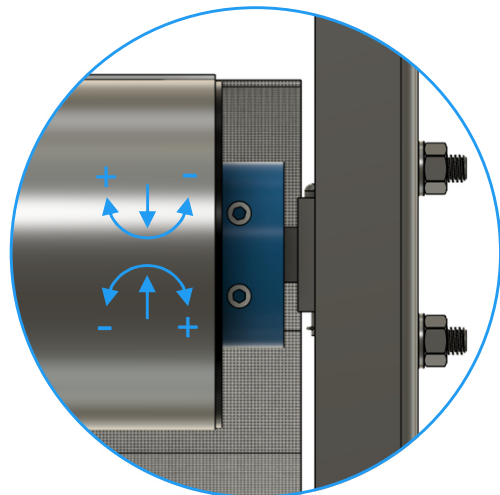

12

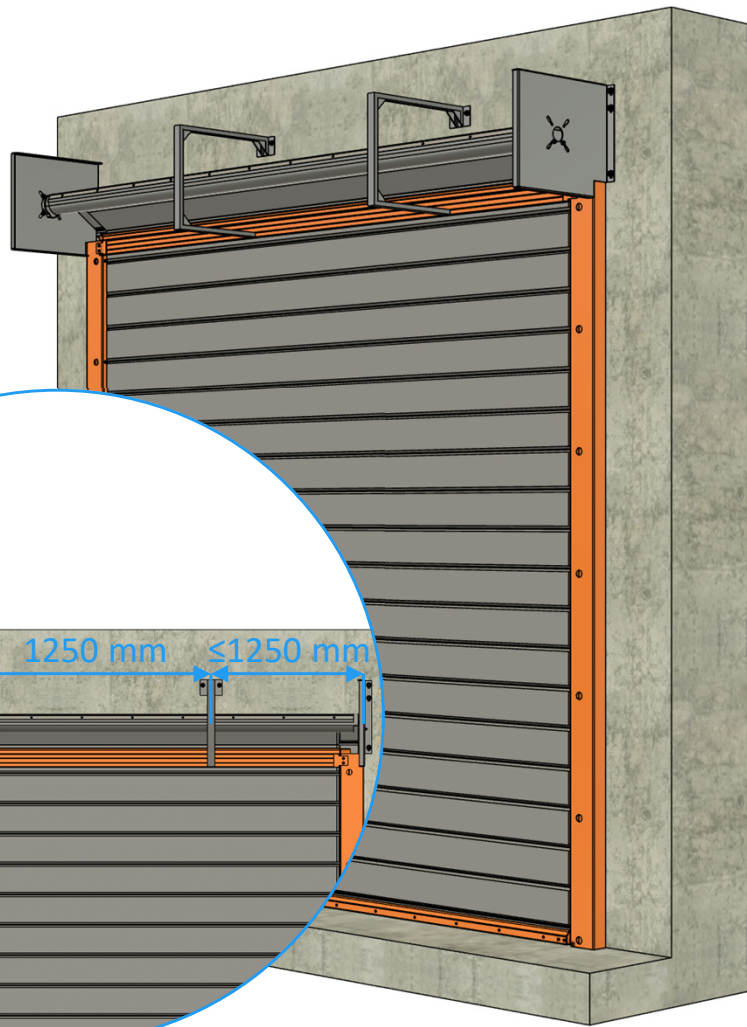
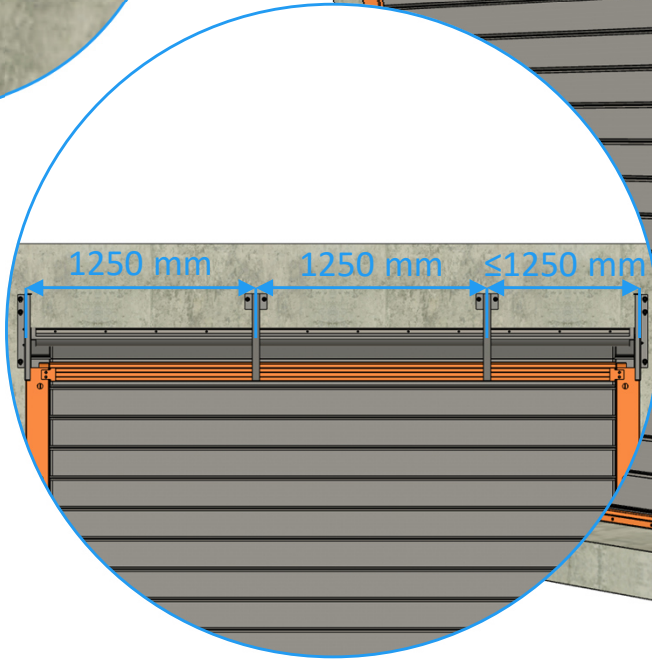
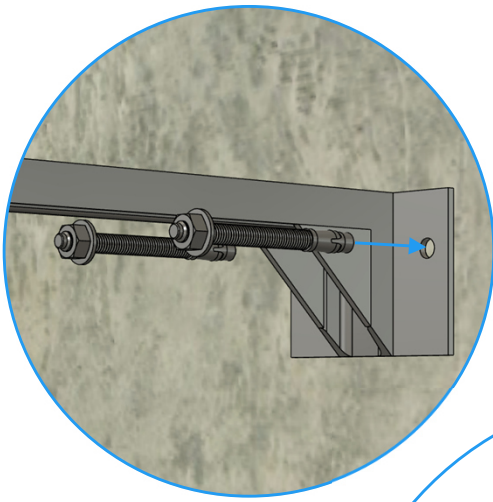

13

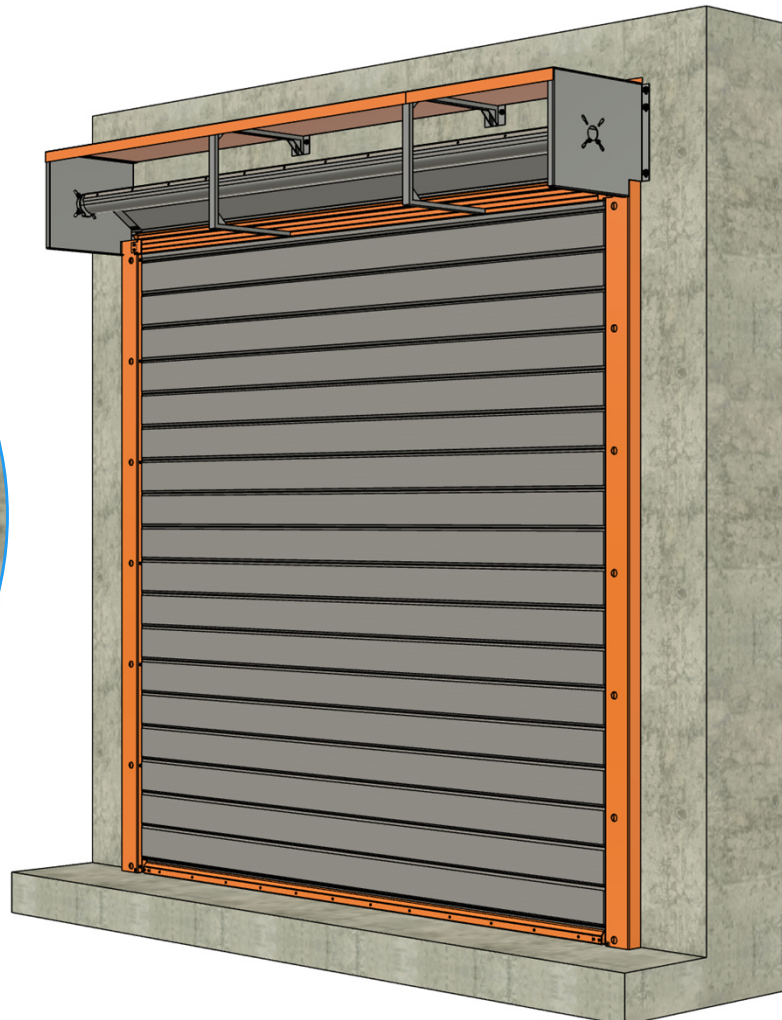
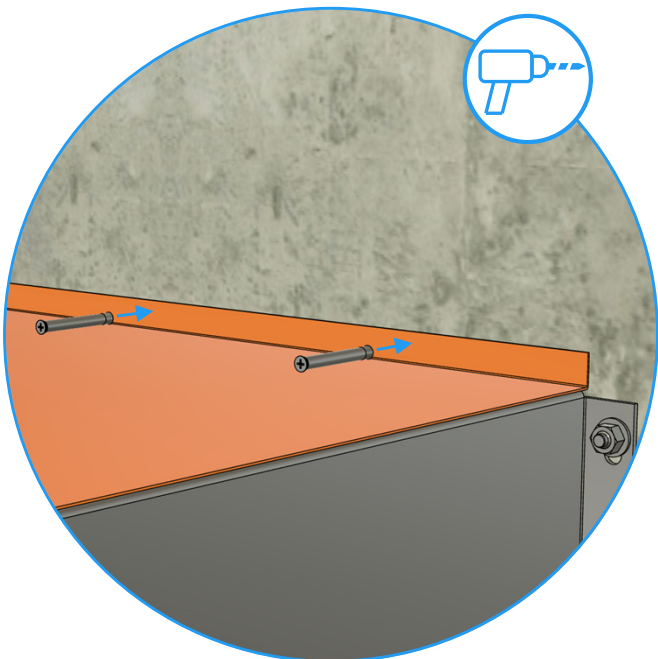

14

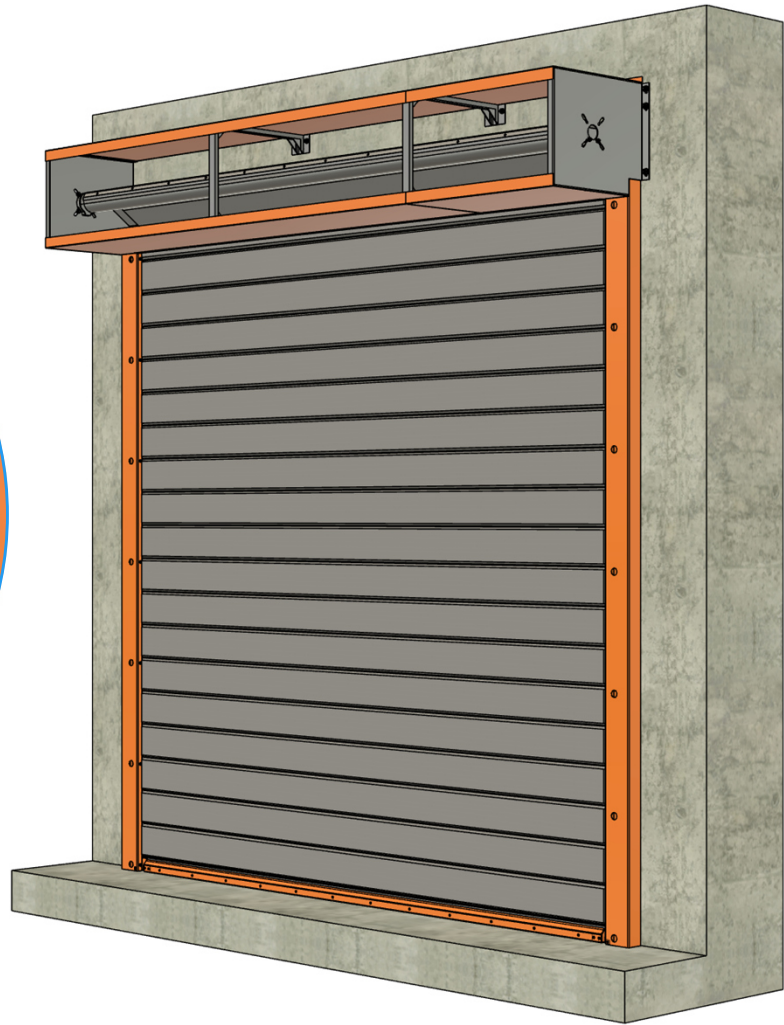
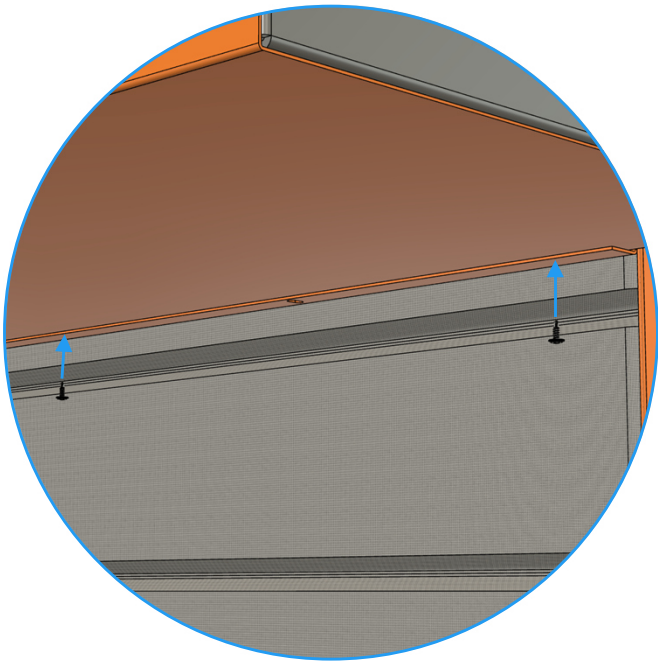

15

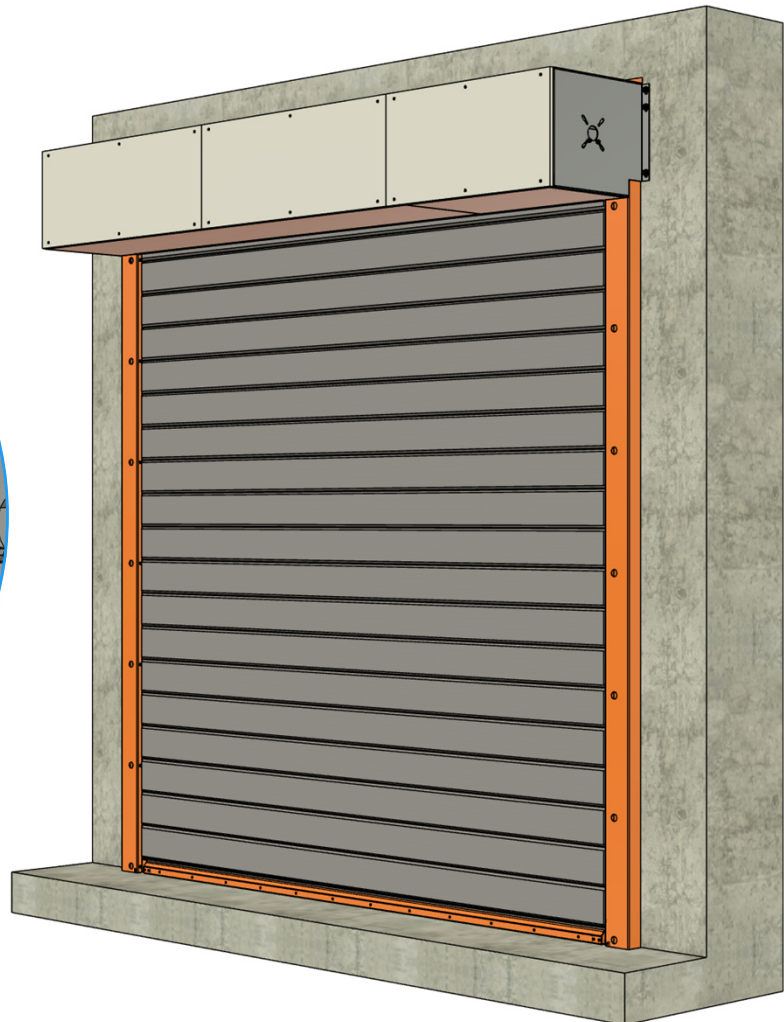
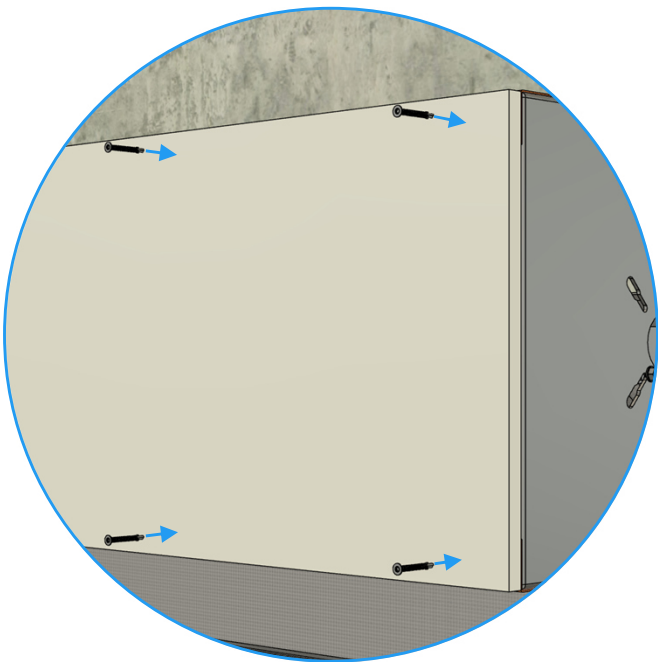

16

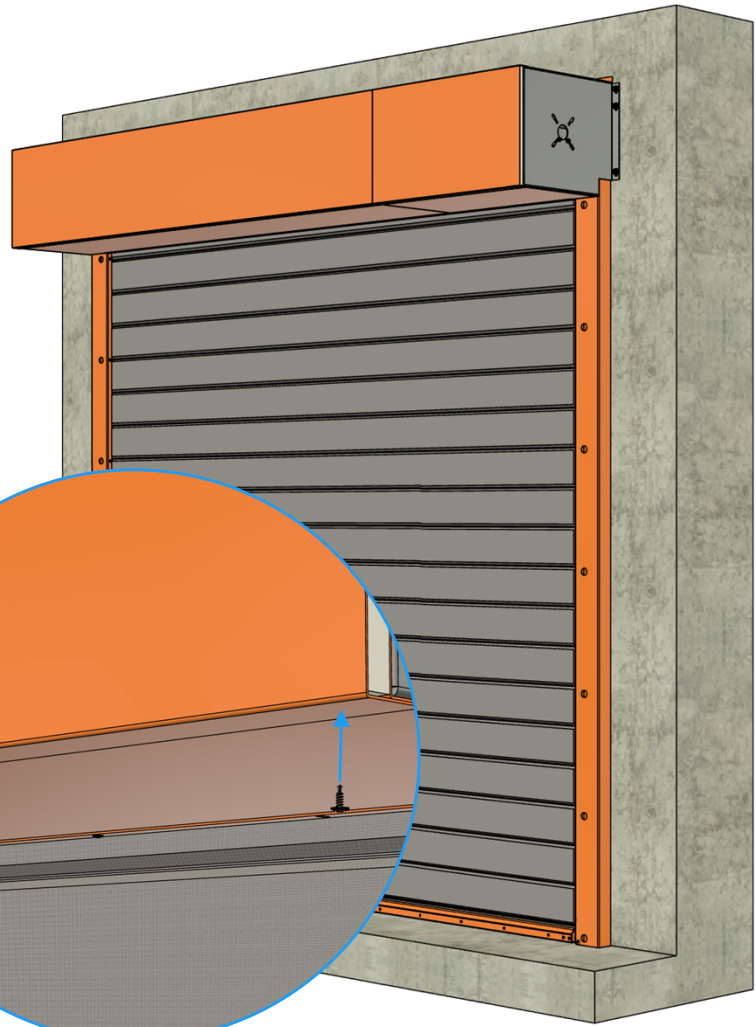
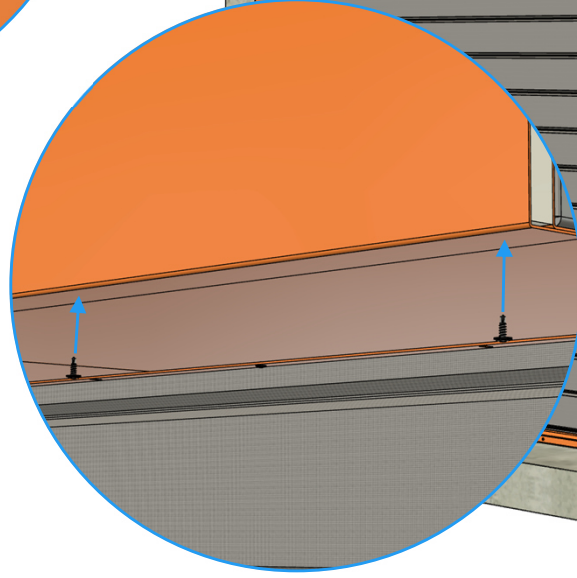
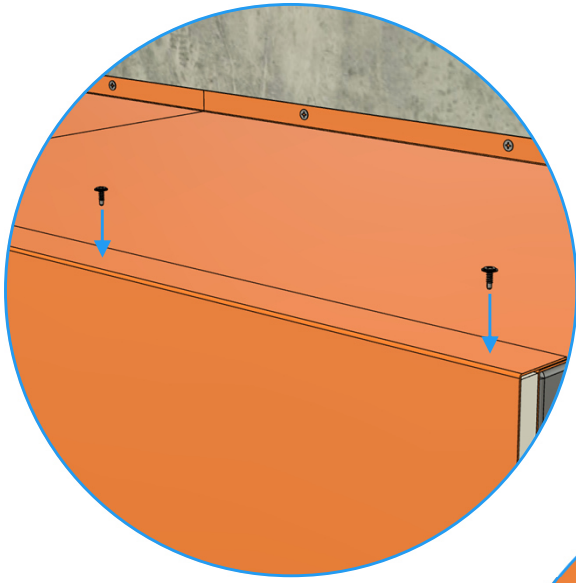

17

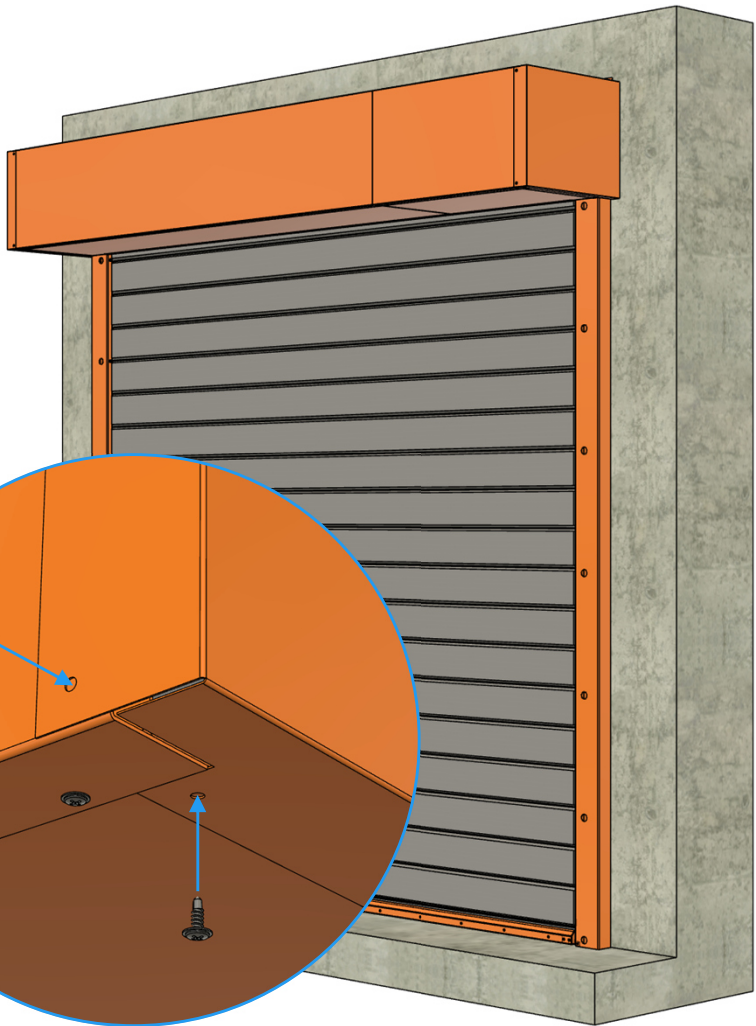
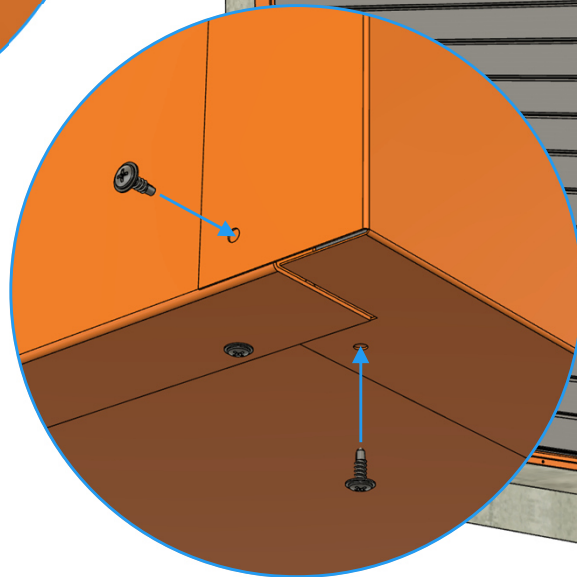
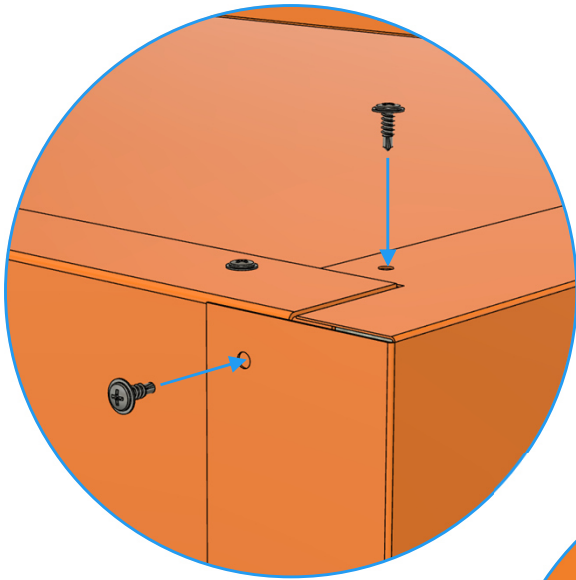

18

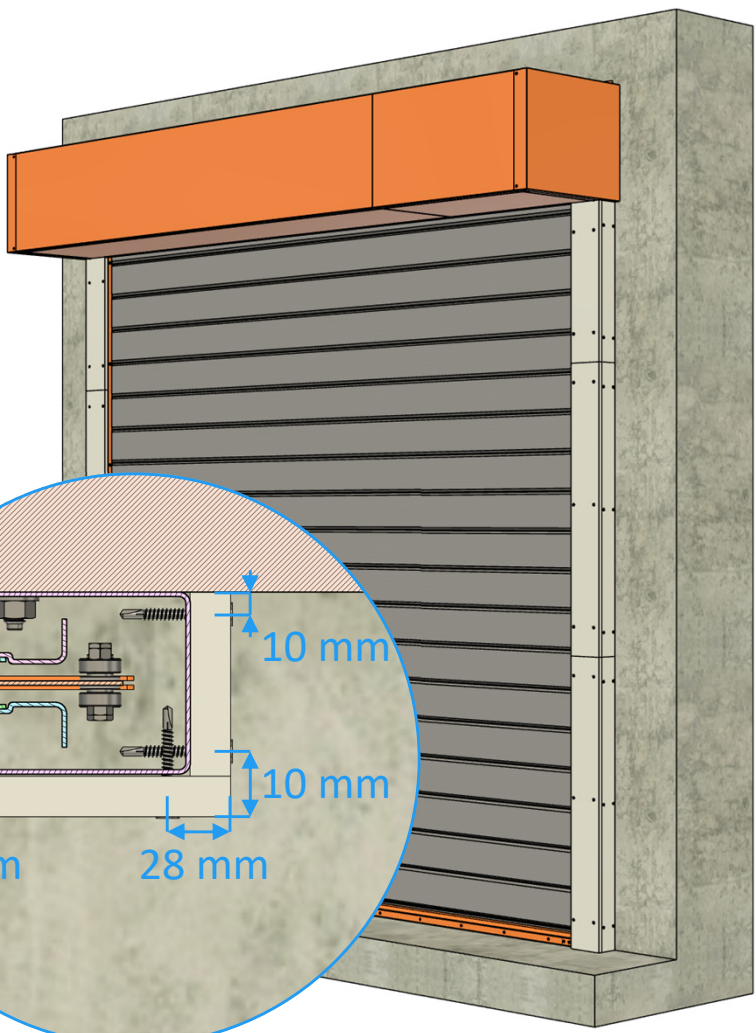
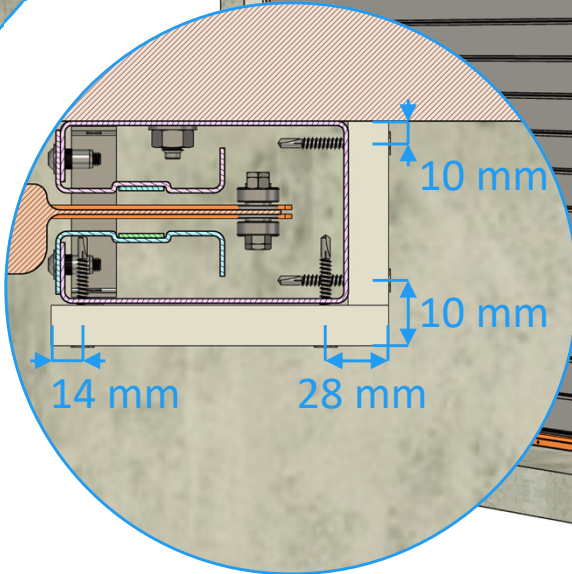
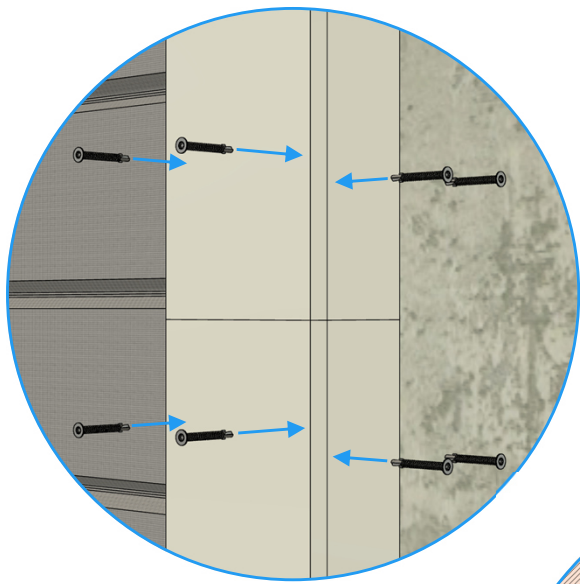

19

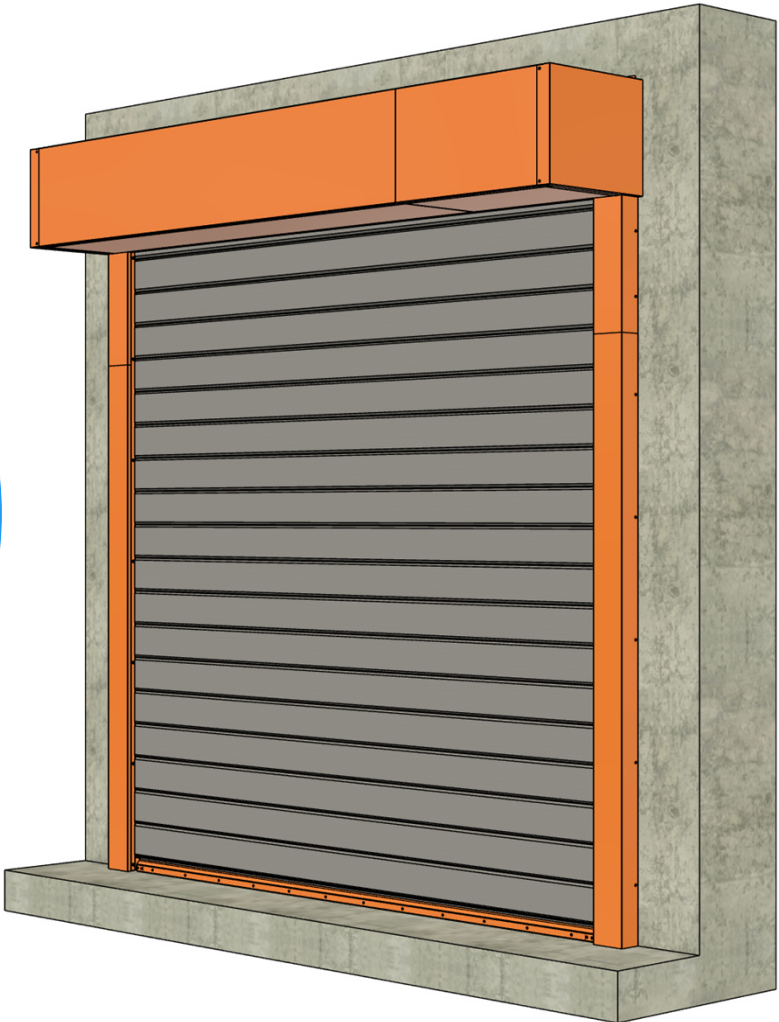
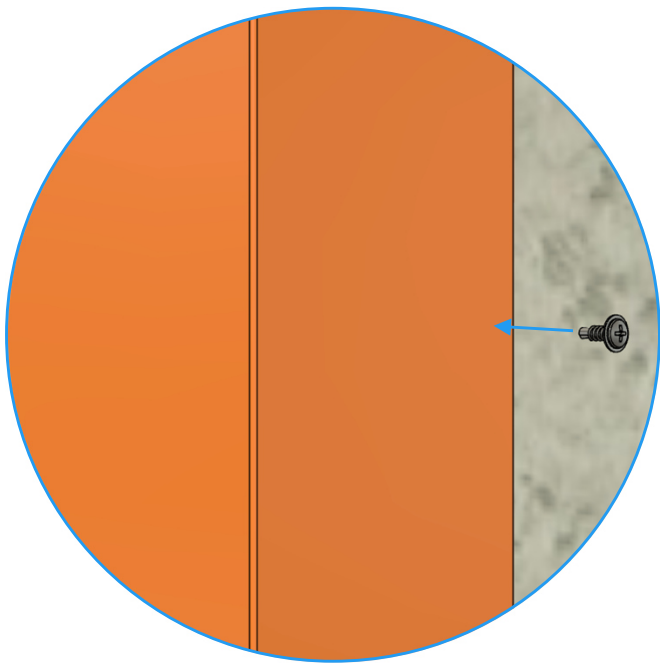



NGR Technologie Sp. z o.o.
ul. Zielonogórska 8 62-065 Grodzisk Wielkopolski
+48 614 445 165, biuro@ngr-technologie.eu